

Fuel shut-off valve - I.S.P.E.S.L. approved

series 541



cert. n° 0003
ISO 9001

01046/03 GB



Product range

Series 541 Threaded version _____ Sizes 1/2" ÷ 2"
Series 541 Flanged version _____ Sizes DN 65 and DN 80
Series 541 High pressure flanged version _____ Sizes DN 65 and DN 80

General

Series 541 (98°C) fuel shut-off valves are made by Caleffi S.p.A. in compliance with the essential safety requirements of Directive 97/23/CE of the European Parliament and the Council of the European Union for the harmonisation of the member states with regard to pressurised equipment.

Function

The Caleffi series 541 fuel shut-off valve is a fail-safe safety device with pre-set calibration. This valve, installed in the burner fuel supply pipework, shuts off the flow of fuel when the temperature of the heat-carrying fluid reaches the calibrated value of the sensor. As this is a fail-safe device in the case of damage to the sensor assembly, the fuel supply pipe is automatically closed. This valve can be used with different types of fuel and is also available in versions for superheated water.



I.S.P.E.S.L.

Technical specification

Materials: - threaded body: brass EN 12165 CW617N
- flanged body: bronze EN 1982 CB491K
- spring: stainless steel
- seals: NBR

Threaded connections: 1/2", 3/4", 1", 1 1/4", 1 1/2" and 2"; FxF
Flanged connections PN 16: DN 65 and DN 80

Sensor pocket connection: 1/2" M

Calibration temperature: 98°C (+0 -5°C) I.S.P.E.S.L. approved
120°C (+0 -5°C) I.S.P.E.S.L. approved
140°C (+0 -5°C) supplied with declaration of conformity
160°C (+0 -5°C) supplied with declaration of conformity
180°C (+0 -5°C) supplied with declaration of conformity

Max temperature: - (sensor side): Calibration temperature + 20%
- (valve side): 85°C

Average working temperature: - threaded: 40°C
- flanged (for gas): 15°C

Max allowed pressure PS: - threaded: 1 bar
- flanged: 0,6 bar

Max working pressure: - (sensor side): 12 bar
- (valve side) threaded: 50 kPa
- (valve side) flanged: 11 kPa
- (valve side) high pressure flanged: 50 kPa

Suitable for following fuels: diesel oil, fuel oil, methane, LPG
PED category: IV

Length of capillary connection tube: 5 or 10 m

Code completion (.)

With 5 m capillary

0 → 98°C	2 → 120°C	4 → 140°C	6 → 160°C	8 → 180°C
----------	-----------	-----------	-----------	-----------

With 10 m capillary

1 → 98°C	3 → 120°C	5 → 140°C	7 → 160°C	9 → 180°C
----------	-----------	-----------	-----------	-----------

Code completion (o)

0 → standard	1 → high pressures
--------------	--------------------

Dimensions

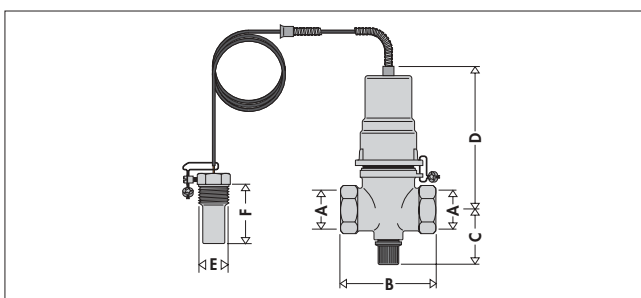

Code	A	B	C	D	E	F	Weight (kg)
54104.	1/2"	72	38,5	112,5	1/2"	43	1,3
54105.	3/4"	72	41	112,5	1/2"	43	1,3
54106.	1"	98	50	123	1/2"	43	2,1
54107.	1 1/4"	98	50	123	1/2"	43	1,9
54108.	1 1/2"	134	57,5	136	1/2"	43	3,6
54109.	2"	134	57,5	136	1/2"	43	3,2

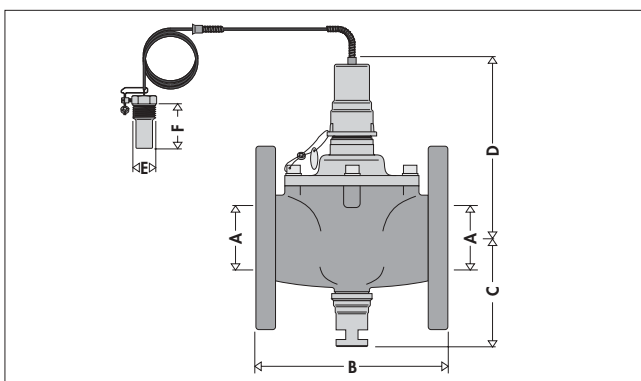

Code	A	B	C	D	E	F	Weight (kg)
5416..	DN 65	180	120	175	1/2"	60	13,6
5418..	DN 80	180	120	175	1/2"	60	15,5

Operating principle

If the calibrated temperature is reached, the vapour pressure sensitive element, with the change of state, causes the actuator to be triggered via the capillary tube and the flexible bellows.

The resetting is achieved by pressing the pushbutton positioned in the lower part of the valve and protected by a plastic cover.

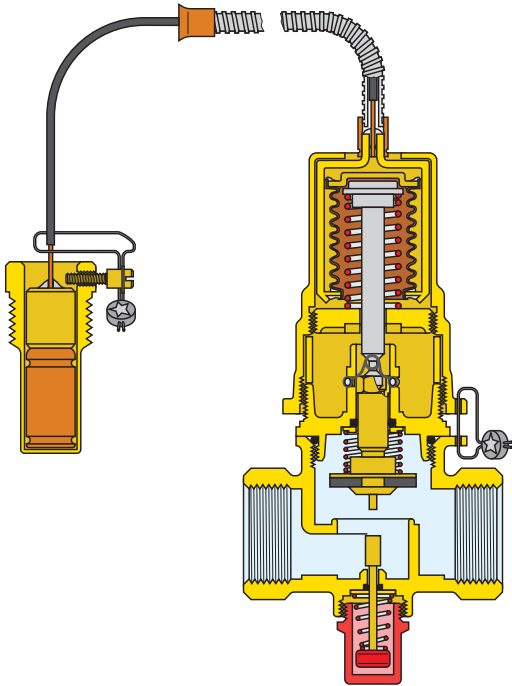

Fluid-dynamic characteristics

Diesel oil at 20°C

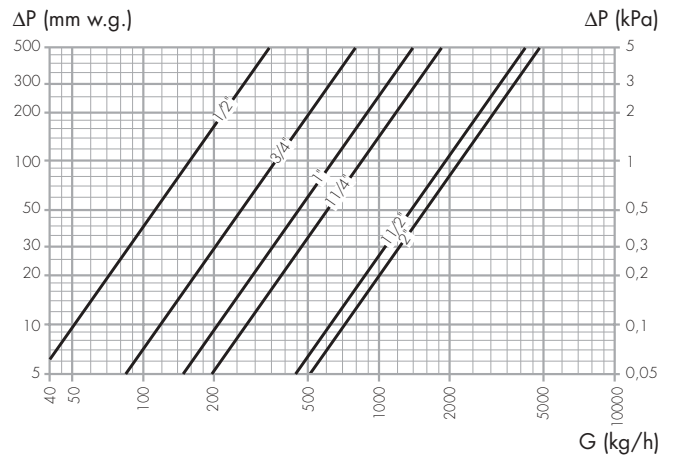

Fuel oil (3÷5 °C at 50°C) at 20°C

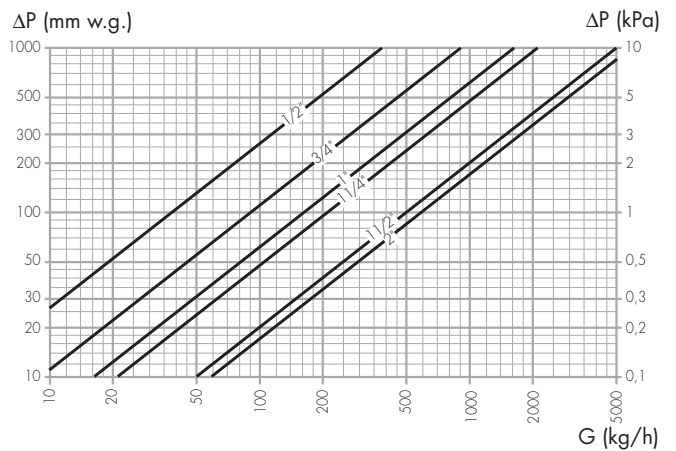

Methane at 15°C

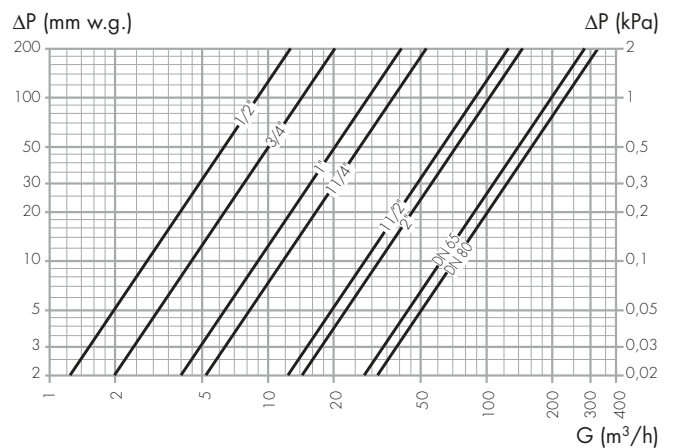

LPG at 15°C

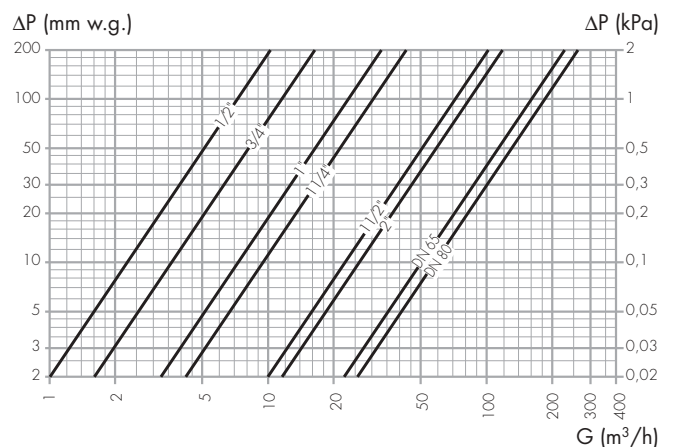

Constructional details

Reset

Should the shut-off device be activated, it has to be reset to its original status as follows:

- Wait until the water temperature falls to 10°C below the shut-off temperature (otherwise it will not be possible to reset the device).
- Unscrew the protective cap.
- Press the reset button.

Series 541 valves are positive action (fail-safe) devices; if the sensor element is damaged or the capillary is broken, the fail-safe action consists of an upward movement of the control unit, thus triggering the actuator, which in turn closes the valve. If this situation occurs, the valve must be replaced.

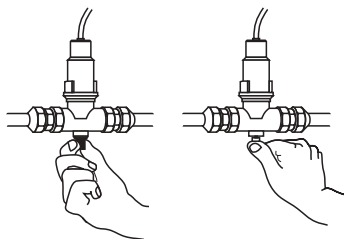

Sensor pocket

The compact dimensions of the pocket make it suitable even for small diameter pipework. In addition, its limited height means that it can be positioned vertically, avoiding difficult installation in the case of bends or near elbows. The superheated water version of the pocket is made of stainless steel.

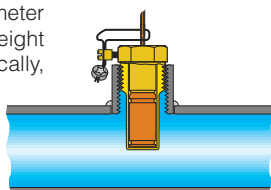

Guideline ratings of boilers (kW)

Size	Diesel oil	Fuel oil	Methane	LPG
1/2"	650	290	30 - 60	50 - 60
3/4"	1.450	580	45 - 90	70 - 80
1"	2.550	1.000	85 - 170	145 - 230
1 1/4"	3.800	1.500	115 - 230	230 - 290
1 1/2"	5.800	2.300	290 - 580	460 - 580
2"	8.100	3.400	340 - 690	520 - 750
DN 65	-	-	460 - 930	1.010 - 1.450
DN 80	-	-	690 - 1.380	1.100 - 1.590

Installation

The fuel shut-off valve must be installed by competent technical personnel qualified in accordance with current legislation.

The valve sensor must be installed at the top of the boiler or in the flow pipework within **0,5 m** of the boiler, upstream of any other shut-off control.

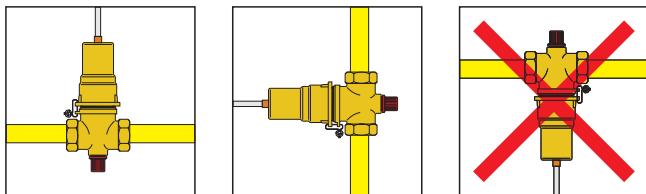

The valve is installed in the fuel supply pipework, in line with the flow direction indicated by the arrow, even if it is in the vertical position.

When installing the device, appropriate precautions must be taken to ensure that the capillary connecting the sensor to the valve does not become squashed or excessively bent.

In order to prevent tampering or accidental leaks of the sensor, the latter must be sealed in the pocket (the seal and the securing wire are included in the package).

References to I.S.P.E.S.L. standards

Series 541, calibration 98°C

Use: hot water systems (temperature < 100°C) - section "R" ed. 82 (R.2.A. 4)

The fuel shut-off valve **is used** in the following types of open vented system:

- Hot water heating systems where the safety pipe runs downwards (R3A 1.14).
- Hot water heating systems in existence on the date of the coming into force of D.M. 1-12-75, where the safety pipe, although having a minimum diameter greater than 18 mm, does not permit discharge into the atmosphere of the maximum quantity of vapour which can be produced in relation to the capacity of the boiler (R3A 3.1).

It is not used in sealed systems:

- In secondary circuits in heat exchangers supplied with fluids at a temperature above 100°C with controls on the secondary or where automatic on/off control is not excluded.

In these cases a temperature relief valve must be installed.

Series 541 calibration 120-140-160-180°C

Use: superheated water systems (temperature >100°C) - section "H" ed. 82 (H.4. 4)

The fuel shut-off device is used in all types of open vented and sealed systems, except for those fed by solid fuel or with heat sources other than fire.

Certification

CE mark

Series 541 (98°C) fuel shut-off valves meet the requirements of Directive 97/23/CE for pressurised equipment (also referred to as the PED).

They are therefore classified in Category IV and granted the CE mark.



I.S.P.E.S.L. mark

The fuel shut-off valve (in our case the valves calibrated to 98°C and 120°C) is a component which is "I.S.P.E.S.L. approved".

Devices of this type are covered by the following types of document:

The approval certificate is the document issued by the I.S.P.E.S.L. which attests to the positive result of the tests carried out on the prototype sample and consequently certifies that the series in question has been approved.

The document is valid for five years. Every item of the series covered by the certificate, which is manufactured during the five years' validity period, is approved for an indefinite period.

The bench calibration report is the document confirming the testing of each individual device included in the approved series.

The test is carried out in the presence of an I.S.P.E.S.L. inspector who draws up the report after the test has been passed.

The document gives the serial number of the valve, which is also to be found on the plate fixed to the valve body.

There is only one copy of the report and it is therefore vital for it to be kept with the valve.

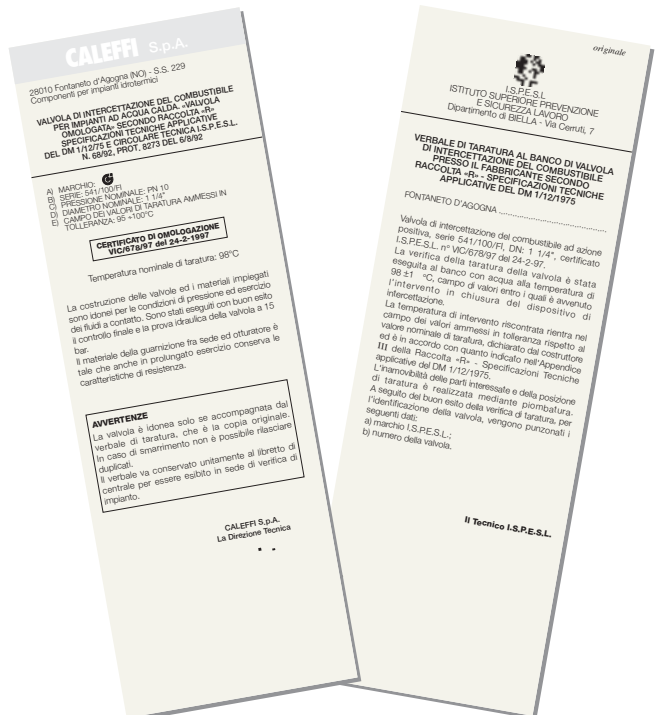

The declaration of conformity is the document issued by the manufacturer which declares that the article in question was made in accordance with the reference standards for I.S.P.E.S.L. approval, but without having had a prototype sample approved. In practice, this is equivalent to a declaration of compliance (i.e. L. 46).

Application diagram

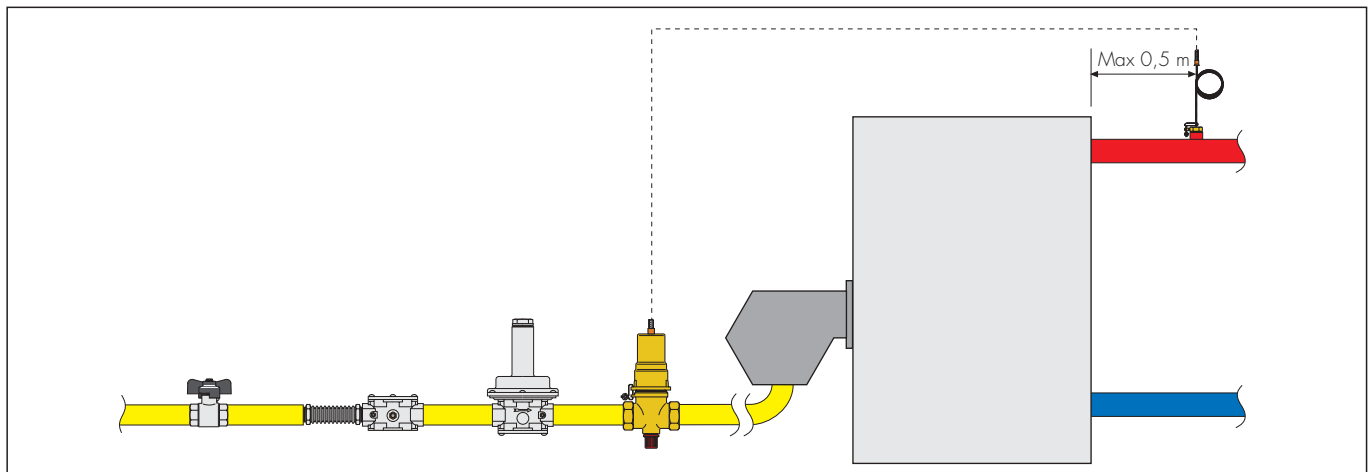

SPECIFICATION SUMMARIES

Series 541. threaded

Manual reset fuel shut-off valve. I.S.P.E.S.L. approved and calibrated. Bearing CE mark as per Directive 97/23/CE (calibration 98°C). Positive action (fail-safe). Calibration 98°C (or 120°C). Threaded connections F x F 1/2" (from 1/2" to 2"). Sensor pocket connection 1/2" M. Brass body. Stainless steel springs. Capillary length 5 m (or 10 m). Maximum temperature (valve side) 85°C. Maximum temperature (sensor side) +20% of calibrated temperature. Maximum working pressure (valve side) using fuel gas 50 kPa. Maximum working pressure (sensor side) 12 bar.

Manual reset fuel shut-off valve. Supplied with declaration of conformity. Positive action (fail-safe). Calibration 140°C (160°C or 180°C). Threaded connections F x F 1/2" (from 1/2" to 2"). Sensor pocket connection 1/2" M. Brass body. Stainless steel springs. Capillary length 5 m (or 10 m). Maximum temperature (valve side) 85°C. Maximum temperature (sensor side) +20% of calibrated temperature. Maximum working pressure (valve side) using fuel gas 50 kPa. Maximum working pressure (sensor side) 12 bar.

Series 541. flanged

Manual reset fuel shut-off valve. I.S.P.E.S.L. approved and calibrated. Bearing CE mark as per Directive 97/23/CE (calibration 98°C). Positive action (fail-safe). Calibration 98°C (or 120°C). Flanged connections PN 16 DN 65 (or DN 80). Sensor pocket connection 1/2" M. Bronze body. Stainless steel springs. Capillary length 5 m (or 10 m). Maximum temperature (valve side) 85°C. Maximum temperature (sensor side) +20% of calibrated temperature. Maximum working pressure (valve side) using fuel gas 11 kPa. Maximum working pressure (sensor side) 12 bar.

Manual reset fuel shut-off valve. Supplied with declaration of conformity. Positive action (fail-safe). Calibration 140°C (160°C or 180°C). Flanged connections PN 16 DN 65 (or DN 80). Sensor pocket connection 1/2" M. Bronze body. Stainless steel springs. Capillary length 5 m (or 10 m). Maximum temperature (valve side) 85°C. Maximum temperature (sensor side) +20% of calibrated temperature. Maximum working pressure (valve side) using fuel gas 11 kPa. Maximum working pressure (sensor side) 12 bar.

Series 541. flanged for high pressures

Manual reset fuel shut-off valve. High pressure version. I.S.P.E.S.L. approved and calibrated. Bearing CE mark as per Directive 97/23/CE (calibration 98°C). Positive action (fail-safe). Calibration 98°C (or 120°C). Flanged connections PN 16 DN 65 (or DN 80). Sensor pocket connection 1/2" M. Bronze body. Stainless steel springs. Capillary length 5 m (or 10 m). Maximum temperature (valve side) 85°C. Maximum temperature (sensor side) +20% of calibrated temperature. Maximum working pressure (valve side) using fuel gas 50 kPa. Maximum working pressure (sensor side) 12 bar.

Manual reset fuel shut-off valve. High pressure version. Supplied with declaration of conformity. Positive action (fail-safe). Calibration 140°C (160°C or 180°C). Flanged connections PN 16 DN 65 (or DN 80). Sensor pocket connection 1/2" M. Bronze body. Stainless steel springs. Capillary length 5 m (or 10 m). Maximum temperature (valve side) 85°C. Maximum temperature (sensor side) +20% of calibrated temperature. Maximum working pressure (valve side) 50 kPa. Maximum working pressure (sensor side) 12 bar.

We reserve the right to change our products and their relevant technical data, contained in this publication, at any time and without prior notice.

